

DEKKER

WALL MOUNTED SPLIT-TYPE AIR CONDITIONERS

SERVICE MANUAL

No.TE100409

Models

DSH 95 R/C

DSH 105 R/C

DSH 135 R/C

DSH 195 R/C

DSH 265 R/C



CONTENTS

1. IMPORTANT NOTICE	2
2. TECHNICAL SPECIFICATION	3
3. OPERATION DETAILS.....	4
4. WIRING DIAGRAM	12
5. EXPLOSION VIEW	15
6. PARTS LIST	20



Большая библиотека технической документации

<https://splitsystema48.ru/instrukcii-po-ekspluatácii-kondicionerov.html>

каталоги, инструкции, сервисные мануалы, схемы.

IMPORTANT NOTICE

This service manual is intended for use by individuals possessing adequate backgrounds of electrical, electronic and mechanical experience. Any attempt to repair the appliance may result in personal injury and property damage. The manufacturer or seller cannot be responsible for the interpretation of this information, nor can it assume any liability in connection with its use.

The information, specifications and parameter are subject to change due to technical modification or improvement without any prior notice. The accurate specifications are presented on the nameplate label.

How to order spare parts

To have your order filled promptly and correctly, please furnish the following information:

1. Model No. with Indoor or Outdoor
2. No. in the Explosion View
3. Part Name
4. The quantity you ordered

Technical Specifications

Model No.		DSH 95 R/C	DSH 105 R/C	DSH 135 R/C	DSH 195 R/C	DSH 265 R/C	
Type		Heating Pump	Heating Pump	Heating Pump	Heating Pump	Heating Pump	
Control type		Remote Controller					
Rated cooling capacity	Btu/h;W	7000	9000	12000	18000	24000	
Rated heating capacity	Btu/h;W	7200	9500	12800	19000	24500	
EER for cooling	Btu/h.w	8.97	8.94	9.01	9.14	9	
COP for heating	W/W	2.89	2.63	2.75	2.75	2.7	
Moisture removal	Liters/h	0.5	0.8	1	1.5	2.4	
Indoor noise level at cooling	High	dB(A)	36	36	37	42	49
	Med.	dB(A)	33	33	34	39	46
	Low	dB(A)	29	29	32	36	42
Outdoor noise level	dB(A)	50	50	52	58	58	
Electrical Data							
Power supply		220-240V~/50Hz/1P					
Voltage Range		V	198~264	198~264	198~264	198~264	198~264
Rated current	Cooling	A	3.6	4.6	6.0	9.0	13.0
	Heating	A	3.3	4.8	6.2	9.2	13.8
Rated input	Cooling	W	780	1010	1330	1970	2600
	Heating	W	730	1060	1360	2020	2800
Refrigerating System							
Refrigerant/Charge		Gram	R22	R22	R22	R22	R22
Compressor		Type	Rotary	Rotary	Rotary	Rotary	Rotary
Evaporator		Hydrophilic & Louver Fin; Innergroover tube type (φ7)					
Condenser		Louver or Corrugated Fin; Innergroover tube type (φ9.52 or φ7)					
Expansion device		Capillary tube					
Defrosting system		Microcomputer controlled reverse system					
Fan System							
Indoor air circulation(Cooling/Heating)		m ³ /h	430	430/430	530/530	800/850	1100/1100
Indoor fan type		Cross flow					
Indoor fan speed H/M/L	Cooling	rpm	1270/1170/1000	1270/1170/1000	1270/1170/1000	1300/1220/1150	1300/1220/1150
	Heating	rpm	1250/1150/1000	1250/1150/1000	1250/1150/1000	1300/1220/1150	1300/1220/1150
	Dry	rpm	1000	1000	1000	1150	1150
	Sleep	rpm	1000	1000	1000	1150/1150	1150
Indoor fan motor output		W	12	12	12	23	35
Outdoor fan type		Propeller					
Outdoor fan speed		rpm	895	895	860	850	840
Outdoor fan motor output		W	25	20	31	55	55
Connections							
Connecting Pipe	Gas	Inches	Φ9.52(3/8")	Φ9.52(3/8")	Φ12.7(1/2")	Φ12.7(1/2")	Φ15.88(5/8")
	Liquid	Inches	Φ6.35(1/4")	Φ6.35(1/4")	Φ6.35(1/4")	Φ6.35(1/4")	Φ9.52(3/8")
Connecting Wiring		Size x Core number	1.0x3; 0.75x2	1.0x3; 0.75x2	1.0x3; 0.75x2	1.5x3; 0.75x2	4x0.75;2x0.75
Drainage Pipe		O.D 16mm					
Others							
Suitable area		m ²	6~10	9~16	15~23	20~35	30~50
Net dimensions (W x H x D)	Indoor	mm	718x240x180	718x240x180	770x240x180	900x280x202	1033x313x202
	Outdoor	mm	600x500x232	600x500x232	700x552x256	820x605x300	820x605x300
Net weight	Indoor	kg	7	7	8	11	14
	Outdoor	kg	23	24	30	41	52
Packing dimensions (W x H x D)	Indoor	mm	805x305x265	805x305x265	855x305x265	995x365x298	1103x400x300
	Outdoor	mm	745x542x353	745x542x353	803x598x380	965x650x438	965x650x438
Gross weight	Indoor	kg	9	9	10	14	17
	Outdoor	kg	26	27	34	45	58

Operation Details

Remote controller

Remote controller

The remote controller transmits signals to the system.

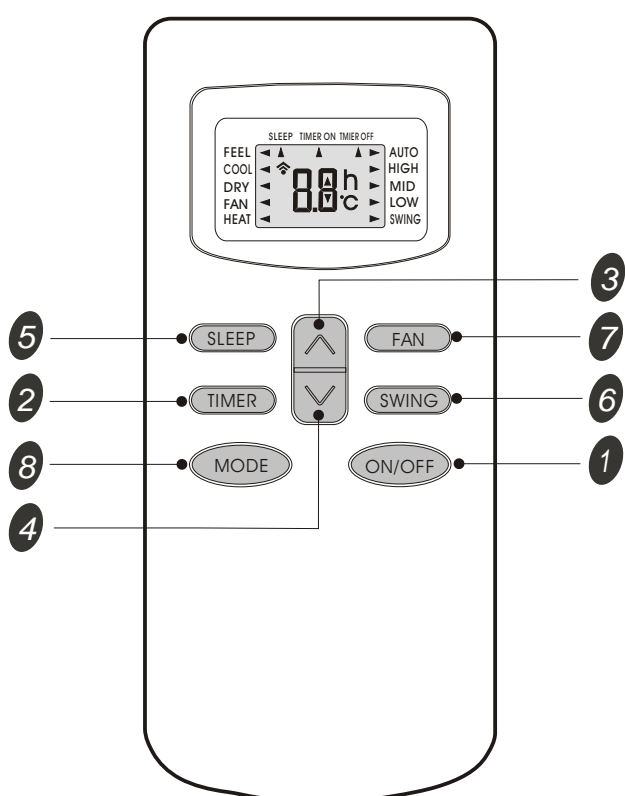

- 1 ON/OFF button**
Used to start and stop operation when pressed.
- 2 TIMER button**
Used to select TIMER operation.
- 3 UP button (TOO COOL button)**
Used to increase the set room temperature and time.
- 4 DOWN button (TOO WARM button)**
Used to decrease the set room temperature and time.
- 5 SLEEP button**
Used to set or cancel sleep mode operation.
- 6 VANE control button**
Used to adjust airflow direction.
- 7 FAN SPEED control button**
Used to select the indoor fan motor speed: Auto, High, Mid and Low.
- 8 MODE button**
Used to select the type of operation mode: Feel, Cooling, Dry, Fan and Heating(Only for Heat Pump).

Note: Each mode and relevant function will be further specified in following pages.

Remote Control

The remote controller is not preset as Cooling Only Air Conditioner or Heat Pump by manufacturer. Each time after the remote controller replace batteries or is energized, the arrowhead will flashes on the front of "Heat" or "Cool" on LCD of the remote controller.

User can preset the remote controller type depending on the air conditioner type you have purchased as follows:

Press any button when the arrowhead flashes on the front of "Cool", Cooling Only is set.

Press any button when the arrowhead flashes on the front of "Heat", Heat Pump is set.

If you don't press any button within 10 seconds, the remote controller is preset as Heat Pump automatically.

Note :

If the air conditioner you purchased is a Cooling Only one, but you preset the remote controller as Heat Pump, it doesn't bring any matter. But if the air conditioner you purchased is a Heat Pump one, and you preset the remote controller as Cooling Only, then you CAN NOT preset the Heating operation with the remote controller.

Electronic controller:**1. Automatic mode**

1) Initial RT determines the working mode and ST, the mode is determined effective only once unless A/C shut-down then re-started. If from other modes switches to autoamatic mode (including mode conversion after shutdown), it should be that the compress stop more than 3 min then temperature judgement and automatic mode are conducted (it can conduct immediately from fan mode switched to automatic, the indoor fan stops, three minutes later the response is made and start up). Within 3 min, the output as: Showing the room temperature, indoor fans starts (or anti-cold airflow), the outdoor fan stops;

2) With memory controller, once being turned off or in case of an accidently power cut, the A/C is able to retain and restore the original mode when being turned on or the power supply is resumed, if the auto restart function activated. power-down after power-on; while if the auto restart fundction isn't activated, the A/C enters standby state.

Heat pump

Mode	Initial RT	Initial ST
Cooling	$RT \geq 26^{\circ}\text{C}$	23°C
Dehumifying	$26^{\circ}\text{C} > RT \geq 20^{\circ}\text{C}$	18°C
Heating	$RT < 20^{\circ}\text{C}$	23°C

Cooling-only

Mode	Initial RT	Initial ST
Cooling	$RT \geq 26^{\circ}\text{C}$	23°C
Dehumifying	$26^{\circ}\text{C} > RT \geq 20^{\circ}\text{C}$	18°C
Ventilating	$RT < 20^{\circ}\text{C}$	—

Under automatic mode (including from automatic converted into dehumidifying Dry mode), when the temperature up and down signals from the remote controller is received, the setting temperature ST adjusts correspondingly to the current room temperature plus or minus 1°C , the automatic regulating temperature range is $\pm 2^{\circ}\text{C}$.

2. Cooling mode

1) The control of the compressor

- When $RT - ST \geq 1^{\circ}\text{C}$, the compressor is running.
- When $RT - ST < -1^{\circ}\text{C}$, the compressor is off.
- When $-1^{\circ}\text{C} \leq RT - ST < 1^{\circ}\text{C}$, the compressor keeps its original state.

2) Outdoor fan motor and the compressor run simultaneously (except for defrosting).

3) The control of indoor fan motor:

- Indoor fan motor can operate by automatic, low, middle, and high airflow speed circularly.
- Indoor fan motor's the automatic airflow speed control Indoor fan motor can operate by automatic, as shown in Figure 1:

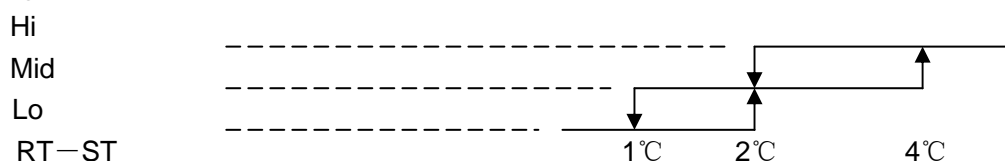

Figure 1 Cooling automatic airflow

When the temperature changes lead to changes in airflow speed, the switch can only be made orderly, and every grade of air flow speed runs 1 minute at least.

3, Dry mode

running into this mode, the Air cond. firstly operates for 3 minutes according to cooling mode (set temperature is 7°C), and then takes the detected backflow air temperature minus 2°C as a new set temperature (the minimum value of 5°C) and runs according to cooling mode, indoor fan operates at low-speed, at this moment the setting operation of Fan speed is invalid but Swing is adjustable.

4. Heating mode

On the Heating mode, the room temperature is repaired. After repaired, the room temperature display on the LED CRT= $\text{RT}-3^{\circ}\text{C}$.

1) The control of the compressor

a. When $\text{ST}-\text{CRT}\geq 1^{\circ}\text{C}$, the compressor is running.

b. When $\text{ST}-\text{CRT}< -1^{\circ}\text{C}$, the compressor is off.

c. When $-1^{\circ}\text{C}\leq\text{ST}-\text{CRT}< 1^{\circ}\text{C}$, the compressor keeps its original state

2) Outdoor fan motor and the compressor run simultaneously (except for defrosting)

3) The control of indoor fan motor:

a. Indoor fan motor can operate by automatic, low, middle, and high airflow speed circularly.

b. indoor fan motor's the automatic airflow speed control Indoor fan motor can operate by automatic, as shown in Figure 2:

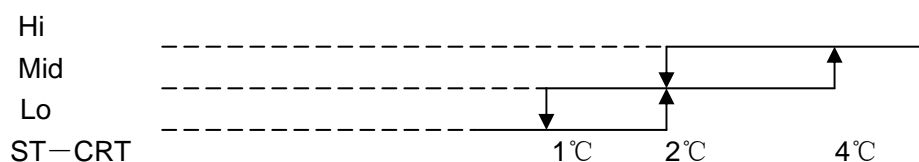

Figure 2 Heating automatic airflow

When the temperature changes lead to changes in airflow speed, the switch can only be made orderly, and every grade of air flow speed runs 1 minute at least.

4) Vane motor control: run as set state.

5) 4-way valve control:

a. Under heating mode, the four-way valve maintains well-connected status (including the compressor stops on set condition, but except for the defrosting process)

b. When the mode switches into the heating mode or start-up, four-way valves will open 5 Seconds before the compressor starts; while the mode exits from the heating mode or turn off, the four-way valve will close 2min after after the shut-down the compressor.

6) Defrosting function:

During defrosting, once mode switch, temperature setting signals received, and the buzzer and display make response immediately, but the other operations won't implemented until defrosting finished;

During defrosting, the signals of on-off, timing, sleep, airflow speed and swing will be responded, but the airflow speed and swing should be in accordance with anti-cold air rules.

Except the above signal processing during defrosting, no other signals will be dealt with, but only a loud buzz.

During defrosting, electrical heating stops compulsively.

Defrosting enter and exit program:

Option 1: with jumper JC

The condition of enter defrosting: run into defrosting once any of condition 1, 2, and 3 met.

Condition 1: As shown in figure 3

Defination:

The followings are all required to meet:

- $IPT1 = IPT_{max} - \Delta IPT$ ($8^{\circ}C$)
- $t5 \geq 50min$ (running time $t5 \geq 50min$ (the compressor runs cumulatively) , $t5$ is removable, and could be less than $t1$)
- $IPT < 40^{\circ}C$, and lasts 2min.

Running into defrosting on condition 1, the first running time of set defrosting is F (8min); after running a defrosting cycle, the defrosting time should be determined and adjusted.

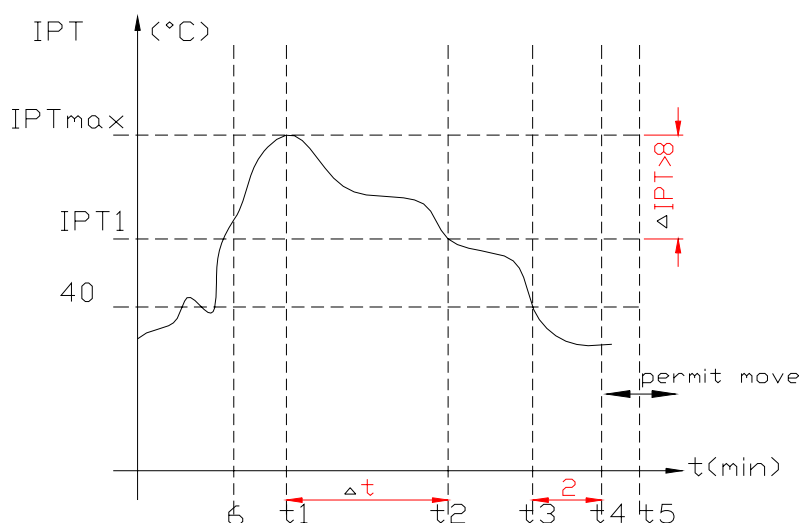

Figure 3

Condition 2: When running time is more than or equal to 120 min (compressor is running accumulatively), the indoor temperature is less than $35^{\circ}C$ for 2 min sustained. Running into defrosting under condition 2, defrosting time set is 8 min.

Condition 3: after the compressor is operating for 20min continuously, the indoor temperature is less than $23^{\circ}C$ which is anti-cold wind temperature when the fan stops running(including temperature dropping when compressor operating, not including the compressor's starting course), and the machine runs into defrosting according to any one condiciton as below) Running into defrosting under condition 3, defrosting time set is 10 min.

- Running into the first defrosting in 20 min after start-up.
- The interval from last defrosting equivalent to or more than 50 min (stopping the compressor or the machine in standby is allowed in the meantime).

Option 2: No Jumper JC, and no OPT outdoor sensor

when the compressor runs for 45 min, if the indoor coil temperature is less than $40^{\circ}C$ for 2 min, the machine runs into defrosting, and lasts for 3min, otherwise when the compressor runs for 120 min, the machine runs into defrosting automatically and last for 10 min.

Option 3: No jumper JC, but with OPT outdoor sensor

When heating, when the temperature of outdoor unit under heat-exchange is lower than $E^{\circ}C$ ($-4^{\circ}C$), and the compressor runs for 45 min, then the machine runs into defrosting and last for 10 min.

Option 4. When heating, when the outdoor fan motor stopped but the compressor not stopped

accumulative total 30min, then the machine runs into defrosting and last for 8 min. if the accumulative total less than 30min, but accord with one of the condition option 1-3 them the machine runs into defrosting at the option 1-3 and the accumulative total time restarts from 0.

Conditions for quitting defrosting

(1) The quitting conditions for option 1 and option 2, the machine quits from defrosting if any one below condition met.

a. Defrosting time is over.

b. When it runs in defrosting for three minutes, the IPT indoor coil temperature rises 15 ° C or above from the bottom point.

(2) The quitting conditions for option 3.

When $OPT \geq 20^\circ\text{C}$ or defrosting for more than 10 min, then quit from defrosting.

(3) Defrosting process shown in Figure 4

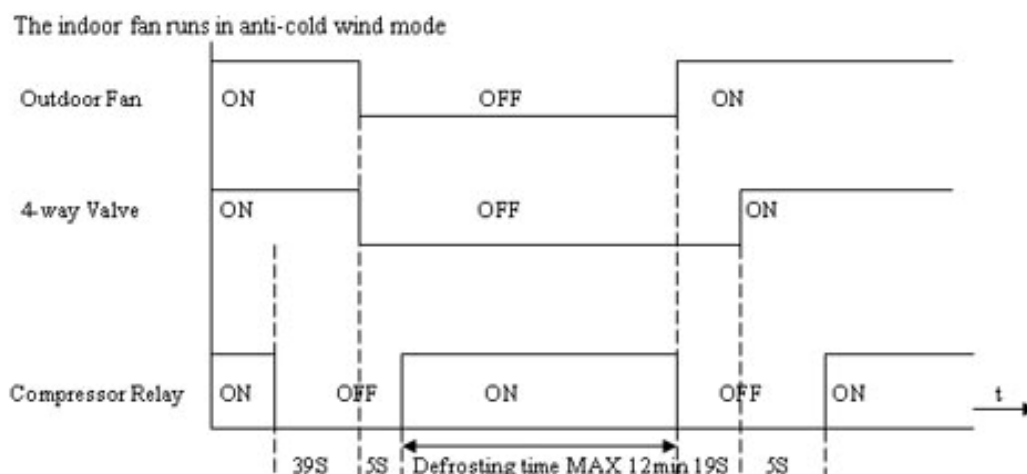

Figure 4 Defrosting process

7) Auxiliary Electric heating function

(1) The default condition is automatic on/off the electric heating function.

(2) The conditions of auxiliary electric heating (all the following conditions must be met)

a. the compressor runs for more than 3min;

b. indoor fan runs normally;

c. not in defrosting state;

d. auxiliary electric heating is turned off for more than 30s.

e. $ST-RT \geq 3^\circ\text{C}$;

f. $RT < 22^\circ\text{C}$;

g. $IPT \leq 43^\circ\text{C}$;

(3) The conditions of stopping auxiliary electric heating (any one of the following conditions met, the state stops)

a. the compressor stops

b. $RT \geq 24^\circ\text{C}$;

c. $IPT \geq 48^\circ\text{C}$

d. indoor fan stops.

e. running into sleeping function

5. Fan mode

1) Indoor fan motor control:

indoor fan motor is running at setting speed (the speed is same as that of heating).

2) Vane motor control: running according to the setting.

3) The outdoor unit is not working under fan mode.

6. Sleeping mode

1) Under sleep mode, the indoor fan motor is running at a low-airflow speed, except that the power light and sleep light are on, timer light is on/off according to the setting state, running light is off. LED is off after displaying 5min.

2) Temperature control:

(1) From cool mode to sleep mode, one hour later, the operates $Temp.=ST+1$, another one hour later, the operates $Temp.=ST+2$, after then unchanged.

(2) From heating mode to sleep mode, one hour later, the operates $Temp.=ST-1$, another one hour later, the operates $Temp.=ST-2$, after then unchanged.

3) the machine will automatically shut up after running 8 hours under sleep mode.

Timer on start-up and sleep mode are implemented at the same time, and the sleep mode can not be functioned.

7. Timing fuction

The timing scale is between 10min to 24h, when the time fixed is less than "10" hours, the displayed time is shown by 0.5 hour as the unit, when the time fixed is more than or equal to "10" hours, the displayed time is shown by 1 hour as the unit.

8. Emergency switch (ON/OFF)

1) When stand-by, to operate by pressing the emergency switch as follows:

To Press the emergency switch in three seconds, the buzzer rings once, and to release, the machine runs into cooling mode; if to holding on, the buzzer rings twince, then the machine runs into heating mode, while when the machine is on, to press the emergency Switch, the buzzer rings once and then the machine shut down.

2) The machine is running mandatorily as the selected mode within 30min after emergency operation, indoor fan motor is running in high-speed, and vane board is swinging. The machine runs into automatic mode 30min later, the selected mode unchanged, the set temperature is 23° C ,the rotate speed of indoor fan motor is automatic, and vane board is swinging too.

3) To press the emergency button when the machine operating, then the machine runs into stand-by state.

4) Under emergency operation, the Compressor's time-lapse protection, anti-frosting protection in cooling, Overheating protection in heating and sensor fault protection and defrost operate are effective.

5) Under emergency operation, once effective signal from remote controller is received, then the machine exits form the emergency mode, and operate according to the setting from remote controller.

9. Auto-restart function

1) The PCB retains the setting parameters in case of power off. When the power supply is resumed, the machine, which has been started up the power-off memory function, is able to restore into the original running state automatically.

2) To press the emergency button and power on, and hold on 10 seconds, exit from the power-off memory function, buzzer rings four tomes.(default: no this function)

10. Protection/ Troubleshooting functions

1) Compressor's protection function:

- a. The PCB which has Power-off memory function, once this function is started up, the compressor goes along 3min delay protection when power on. If the PCB hasn't been started up this function, even when the PCB is power-on, the compressor doesn't process 3 min delay function.
- b. Compressor's 3 min interval protection: the compressor can't start-up until 3 min later(except for defrosting process).
- c. After the compressor started, the compressor's state isn't subject to the changes on ST,RT in 3min.

2) Anti-frosting protection of indoor evaporator:

If $IPT \leq 0\text{ }^{\circ}\text{C}$ detected in consecutive 5 min, compressor and outdoor motor stoped, indoor fan motor runs at high-speed forcibly; $IPT \geq 5\text{ }^{\circ}\text{C}$ detected 3min later, then outdoor fan is activated. And the compressor, indoor fan motor restores the original state.

3) Overheating protection:

$IPT \geq 55\text{ }^{\circ}\text{C}$, the outdoor fan stops, $IPT \geq 65\text{ }^{\circ}\text{C}$, the compressor stops, indoor fan motor runs at high-speed forcibly. When $IPT \leq 48\text{ }^{\circ}\text{C}$, outdoor fan motor and the compressor open, indoor fan motor restores the original state.

4) Anti-cold wind control in heating:

- a. When runing into the heating mode, once the compressor fails to comply with the start-up conditions, the wind speed is regulated according to the coil temperature in 2 min(including stopping the indoor fan motor), 2 min later the indoor fan motor stops.If the compressor starts up within 2 min, then operating by Figure 5.

Under heating process, to close the compressor (including the downtime protection), the wind speed is regulated according to the coil temperature in 1min(including stopping the indoor fan), 1min later the fan is stoped forcibly.

- b. When the indoor fan motor running at a low-speed wind and in anti-cold wind operation, once electric heating opens,the vane immediately withdraws from the anti-cold windy location and turn back to normal vane angle. When electric heating closes, indoor fan motor go on to run at low-speed wind, accordingly, the vane turns to anti-cold windy location.

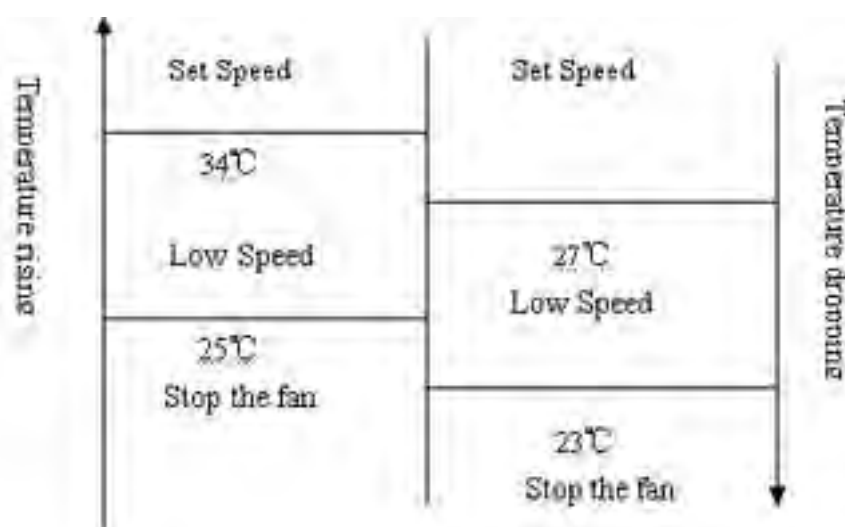

Figure 5 Anti-cold Wind

- 2) The following table shows the fault protections. When failures happens, the PCB alarms and buzzer rings three times. Failure code appears, and the PCB operates protection procedures.

Failure code: For the machine has LED, the code displays on LED, for no LED machine, the code reflects by the running light.

Failure	Running Light Flash	LED Display
RT Sensor Failure	Once / Period	E1
IPT Sensor Failure	Twice / Period	E2
Indoor Fan Motor Failure	6 times / Period	E6

When there is LED displaying failure code, the code is displayed statically, if there are several failure codes should be reported at the same time, then failure codes appears one by one every eight seconds correspondingly.

a. Sensor's failure protection: when the sensor's temperature is out of the range $-50 \leq T \leq 110$ °C, then sensor failure is determined. Once RT, IPT sensor failures appear, the compressor stops and indoor and outdoor fan motors shut off. Remote controller doesn't response to any signal except for shutdown. During failure the machine can run in fan mode. After the failure is settled, the PCB restores to standby status.

b. Failure protection of Indoor PG fan motor: If there is no feedback signal of rotate speed within 5, the indoor fan motor stops, at the same time, the compressor, outdoor fan motor, four-way valve and auxiliary electric heater etc cut down. 10 seconds later, the indoor fan motor restarts, once there is no feedback signal of rotate speed within 5 seconds either, then the machine stops and goes into indoor fan motor failure protection, buzzer rings three times, and running light flashes at 6 times per 8 seconds. When the failure is confirmed, once there is feedback signal, the failure is relieved automatic.

WIRING DIAGRAM

MODEL: DSH 95 R/C, DSH 105 R/C, DSH 135 R/C

INDOOR UNIT:

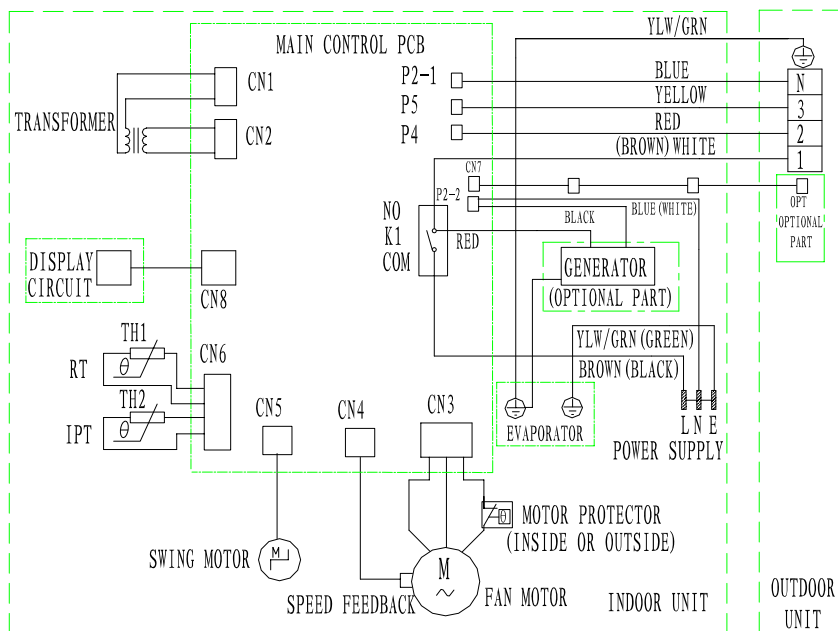

OUTDOOR UNIT

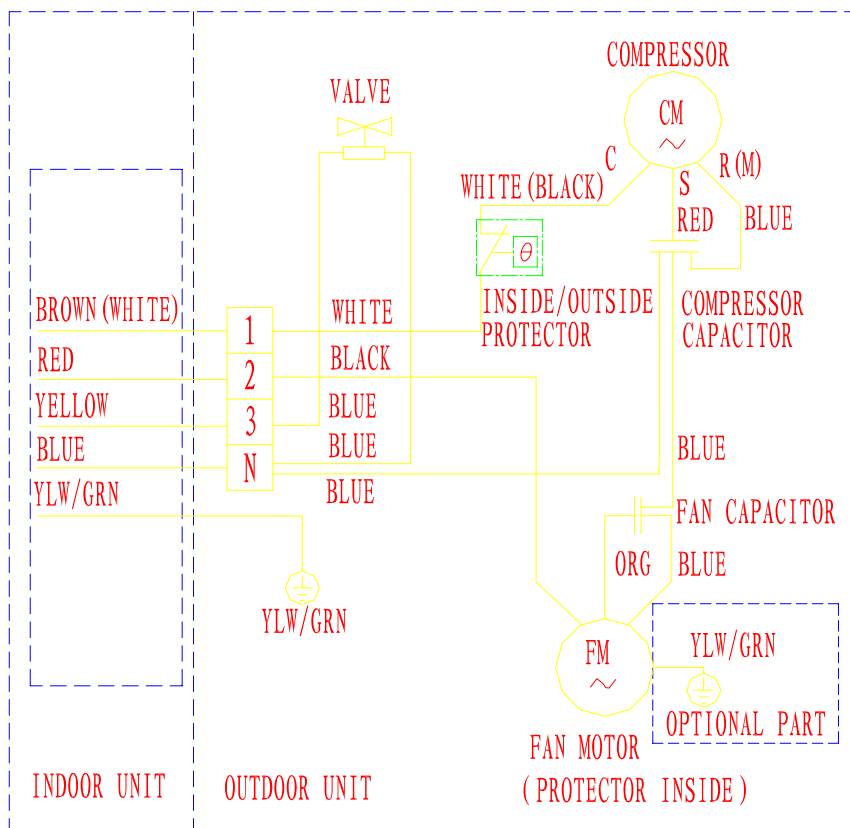

WIRING DIAGRAM

MODEL:DSH 195 R/C

INDOOR UNIT:

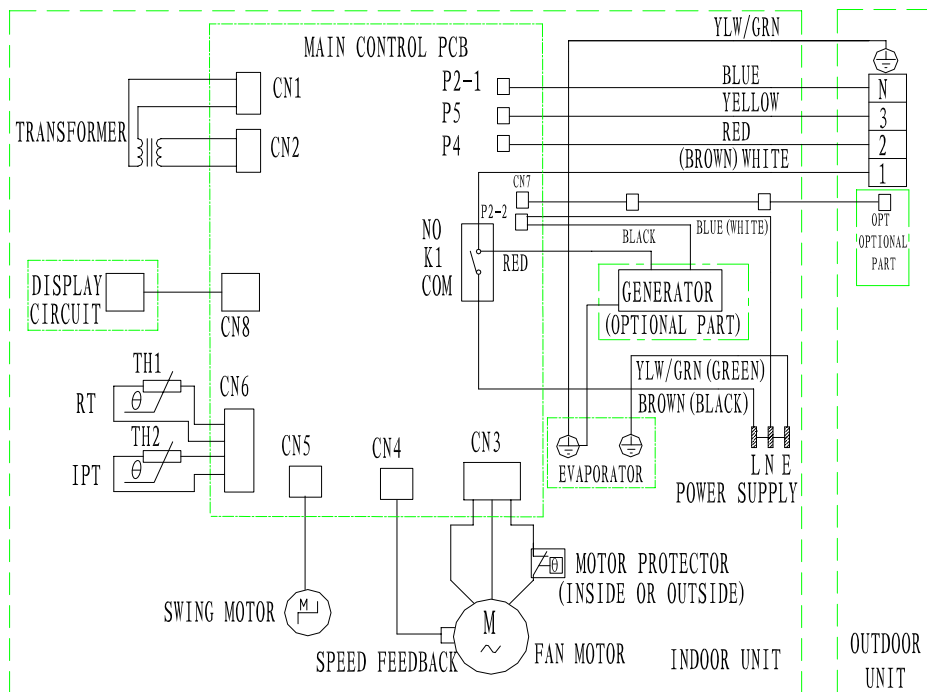

OUTDOOR UNIT

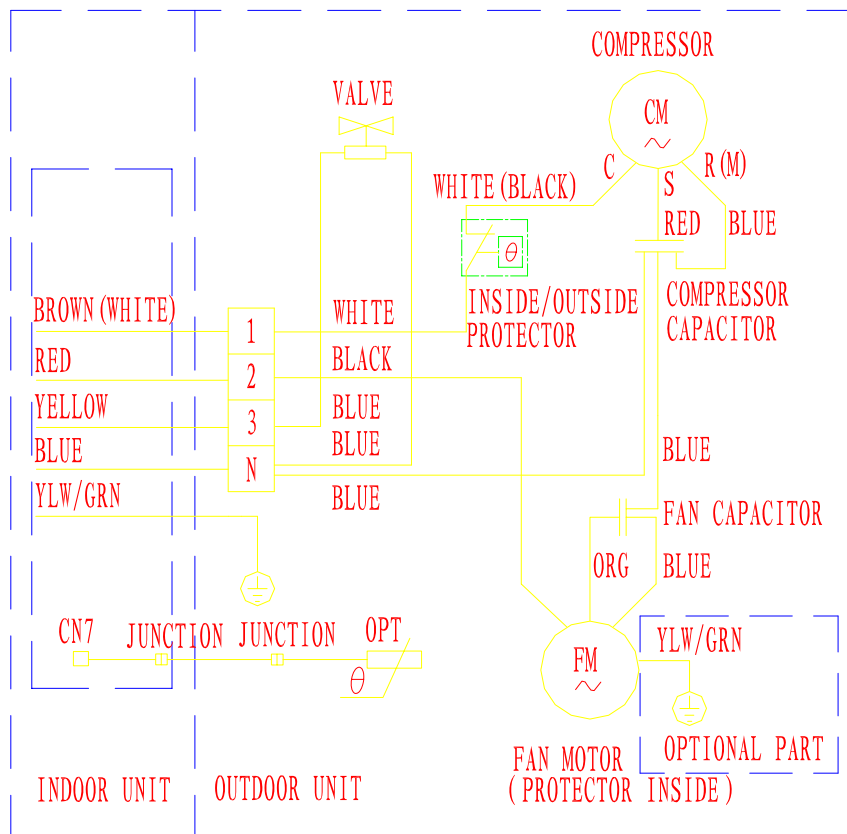

WIRING DIAGRAM

MODEL:DSH 265 R/C
INDOOR UNIT:

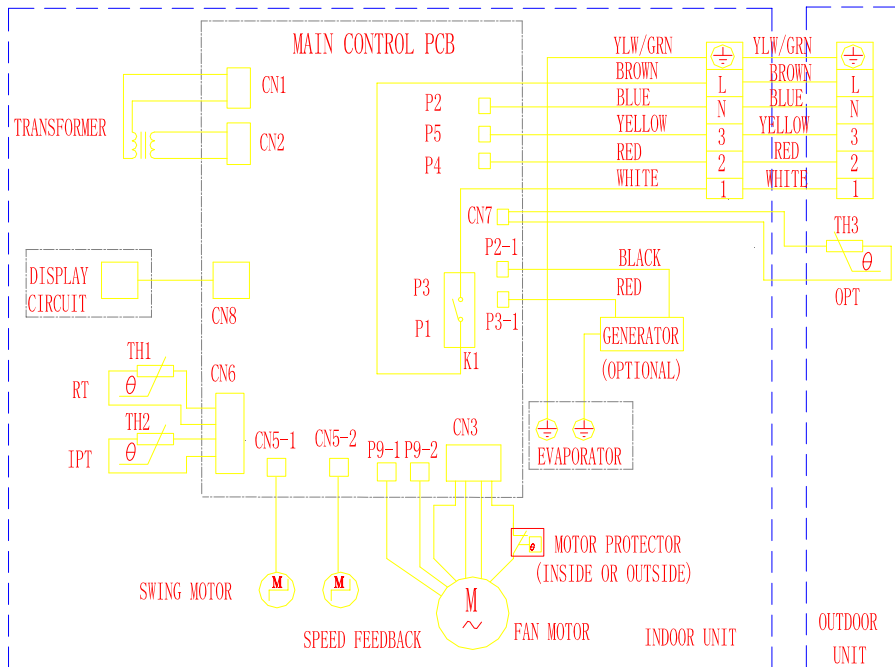

OUTDOOR UNIT

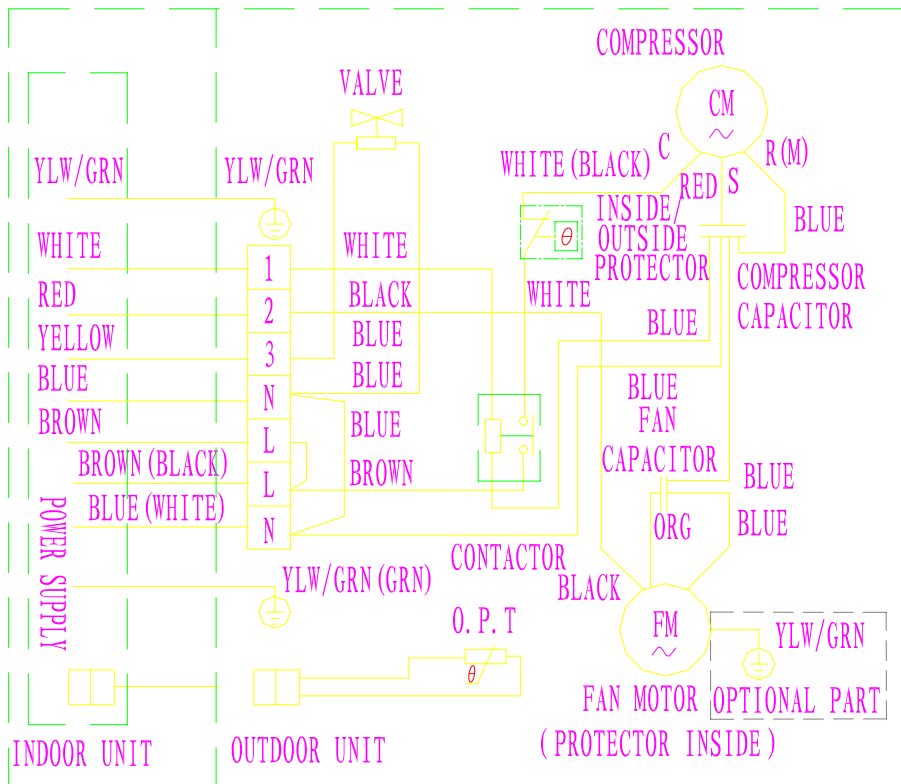

EXPLOSION VIEW

INDOOR UNIT:

MODEL: DSH 95 R/C, DSH 105 R/C, DSH 135 R/C, DSH 195 R/C

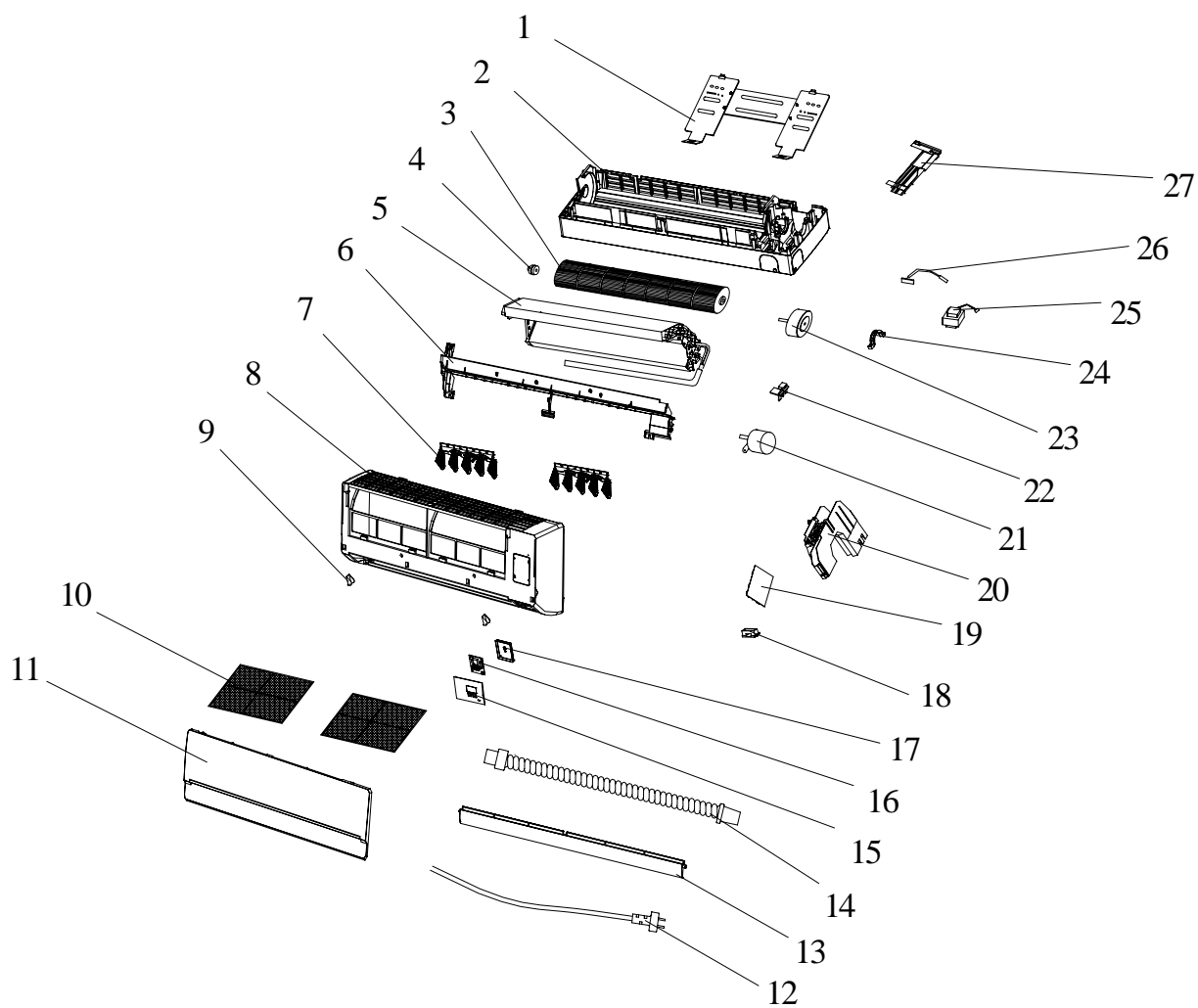

EXPLOSION VIEW

INDOOR UNIT:

MODEL: DSH 265 R/C

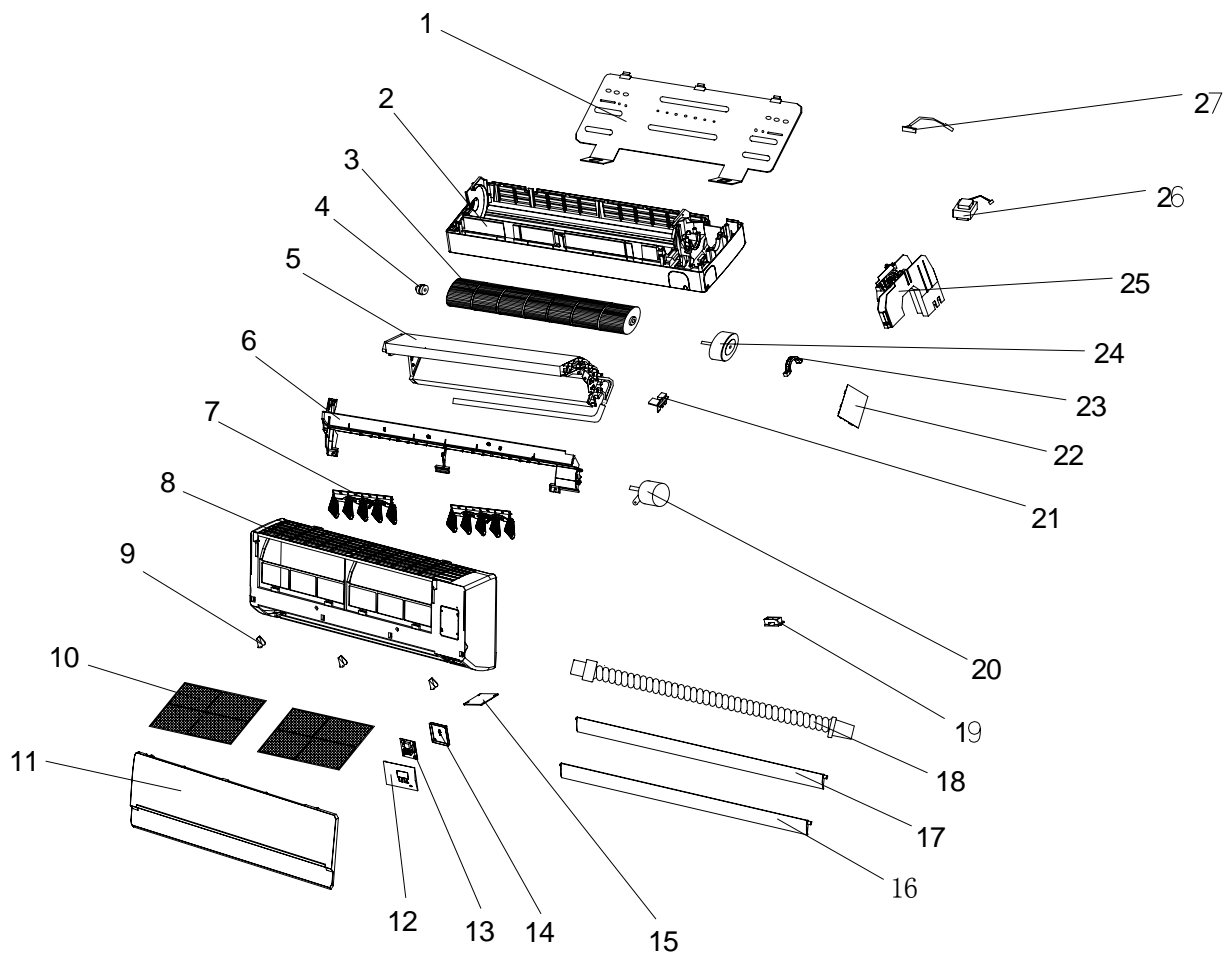

EXPLOSION VIEW

OUTDOOR UNIT:
MODEL: DSH 95 R/C

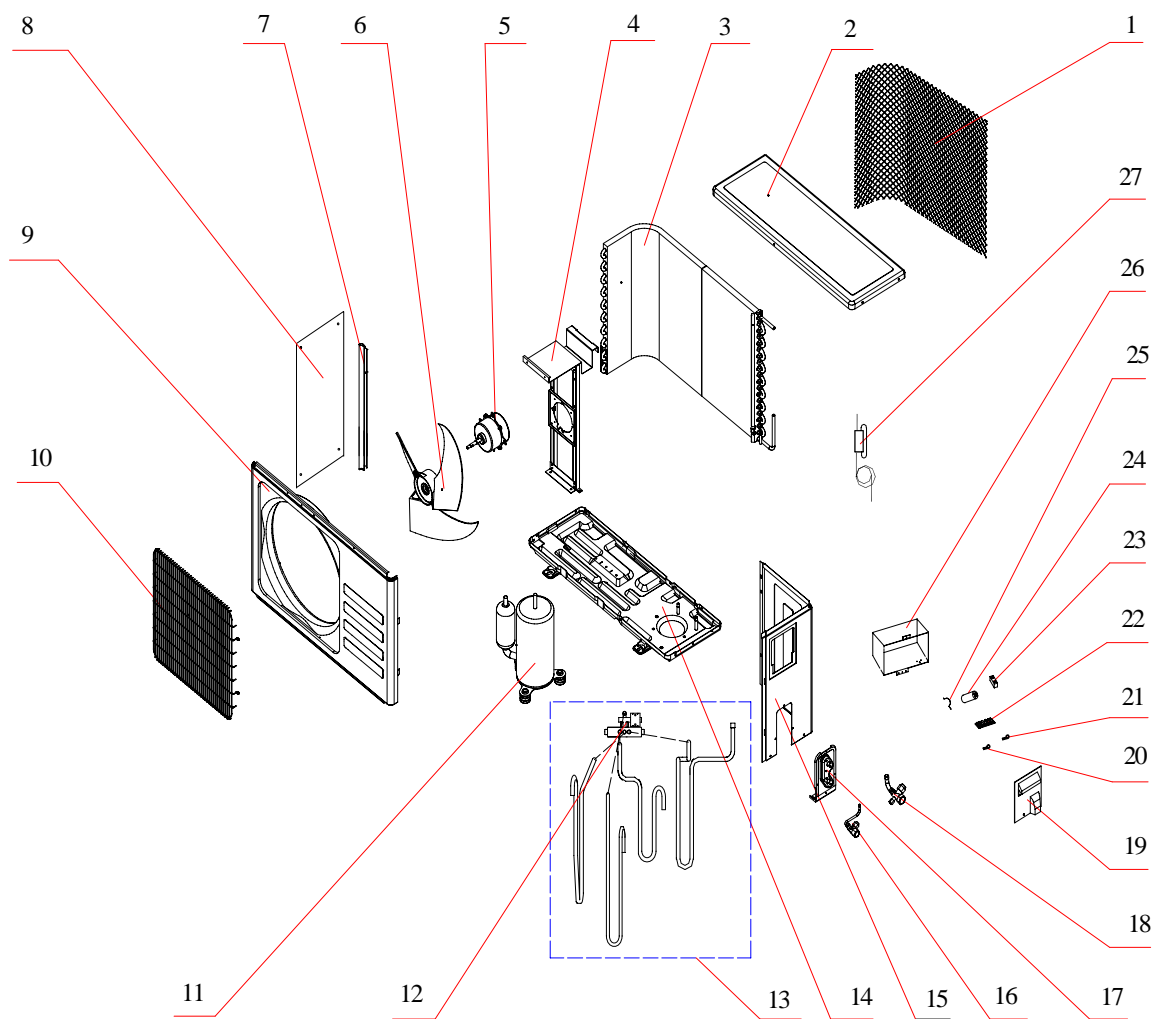

EXPLOSION VIEW

MODEL: DSH 105 R/C, DSH 135 R/C, DSH 195 R/C

OUTDOOR UNIT:

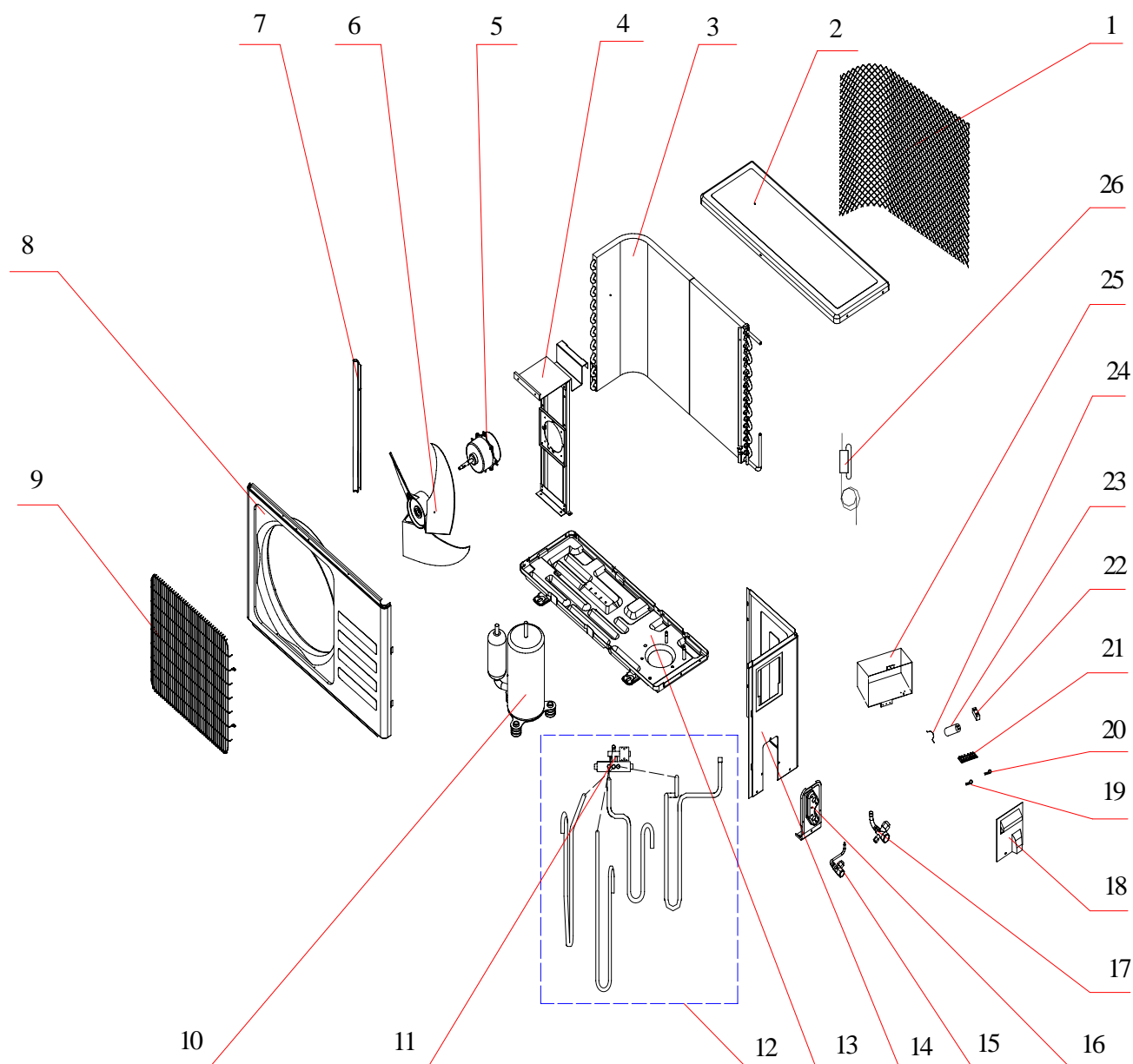

EXPLOSION VIEW

MODEL: DSH 265 R/C

OUTDOOR UNIT:

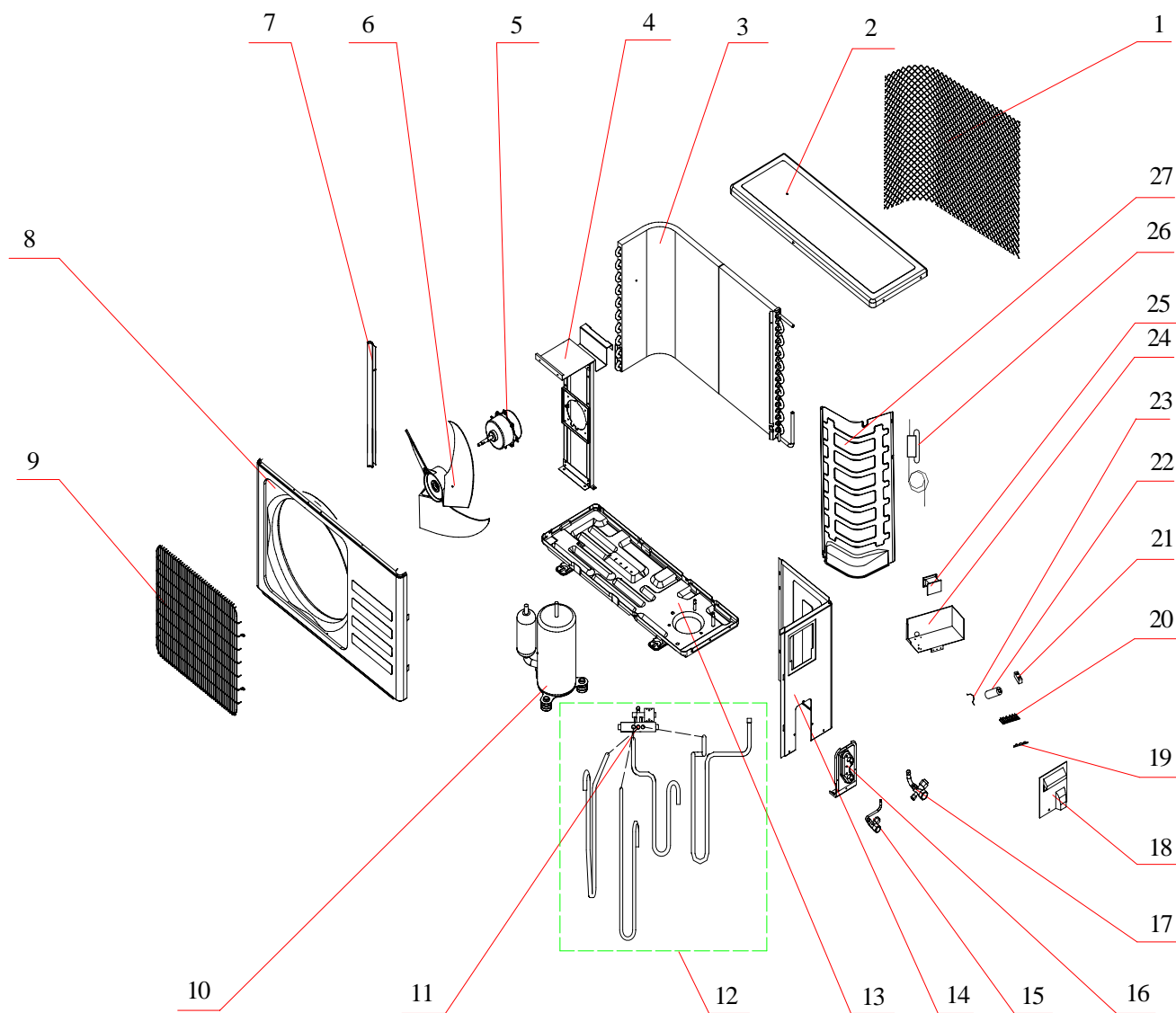

Indoor Unit- DSH 95 R/C

No.	Part No.	Part Name	Q'ty	Remark
1	1080030003	Installation Plate	1	
2	1210250103	Base	1	
3	1070020017	Cross Fan	1	
4	1070100010	Bearing Mount	1	
5	1210231201	Evaporator	1	
6	1070251833	Water Drainage Assembly	1	
7	1070321035	Vertical Vane Assembly	2	
8	1070251841	Face Frame	1	
9	1070320112	Screw Cover	2	
10	1070250106	Air Filter	2	
11	1070251941	Front Panel	1	
12	1170120042	Power Supply Cord	1	
13	1070251837	Vane	1	
14	1070110011	Drainage Hose	1	
15	1070321024	Display PCB Cover	1	
16	1090320291	Display PCB(Digital)	1	
17	1070321181	Display PCB Box	1	
18	1070040004	Cable Clamp	1	
19	1170020011	Vane Motor	1	
20	1090250016	Main PCB(Digital)	1	
21	1073030201	Sensor Holder	1	
22	1070320113	Electrical Box	1	
23	1070320111	Indoor Motor Cover	1	
24	1170030047	Indoor Motor	1	
25	1170240001	Transformer	1	
26	1170230001	Indoor Sensor Assembly	1	
27	1070320101	In And Out Pipe Fixer	1	
29	1090050649	Remote Controller	1	Not shown in Explosion view
29	1070060003	Remote Controller Supporter	1	
30	1190250885	Indoor Carton	1	
31	1191990102	Left Foaming	1	
32	1191990103	Right Foaming	1	

Indoor Unit- DSH 105 R/C

No.	Part No.	Part Name	Q'ty	Remark
1	1080030003	Installation Plate	1	
2	1210250103	Base	1	
3	1070020017	Cross Fan	1	
4	1070100010	Bearing Mount	1	
5	1210231201	Evaporator	1	
6	1070251833	Water Drainage Assembly	1	
7	1070321035	Vertical Vane Assembly	2	
8	1070251841	Face Frame	1	
9	1070320112	Screw Cover	2	
10	1070250106	Air Filter	2	
11	1070251941	Front Panel	1	
12	1170120042	Power Supply Cord	1	
13	1070251837	Vane	1	
14	1070110011	Drainage Hose	1	
15	1070321024	Display PCB Cover	1	
16	1090320291	Display PCB(Digital)	1	
17	1070321181	Display PCB Box	1	
18	1070040004	Cable Clamp	1	
19	1170020011	Vane Motor	1	
20	1090250016	Main PCB(Digital)	1	
21	1073030201	Sensor Holder	1	
22	1070320113	Electrical Box	1	
23	1070320111	Indoor Motor Cover	1	
24	1170030047	Indoor Motor	1	
25	1170240001	Transformer	1	
26	1170230001	Indoor Sensor Assembly	1	
27	1070320101	In And Out Pipe Fixer	1	
29	1090050649	Remote Controller	1	Not shown in Explosion view
29	1070060003	Remote Controller Supporter	1	
30	1190250885	Indoor Carton	1	
31	1191990102	Left Foaming	1	
32	1191990103	Right Foaming	1	

Indoor Unit- DSH 135 R/C

No.	Part No.	Part Name	Q'ty	Remark
1	1080030008	Installation Plate	1	
2	1210320107	Base	1	
3	1070020026	Cross Fan	1	
4	1070100010	Bearing Mount	1	
5	1210320601	Evaporator	1	
6	1070321032	Water Drainage Assembly	1	
7	1070321035	Vertical Vane Assembly	2	
8	1070321030	Face Frame	1	
9	1070320112	Screw Cover	2	
10	1070250106	Air Filter	2	
11	1070322132	Front Panel	1	
12	1170120045	Power Supply Cord	1	
13	1070321034	Vane	1	
14	1070110011	Drainage Hose	1	
15	1070321024	Display PCB Cover	1	
16	1090320291	Display PCB(Digital)	1	
17	1070321181	Display PCB Box	1	
18	1070320114	Cable Clamp	1	
19	1300321241	Main PCB(Digital)	1	
20	1070320113	Electrical Box	1	
21	1170020011	Vane Motor	1	
22	1073030201	Sensor Holder	1	
23	1170030047	Indoor Motor	1	
24	1070320111	Indoor Motor Cover	1	
25	1170240001	Transformer	1	
26	1170230001	Indoor Sensor Assembly	1	
27	1070320101	In And Out Pipe Fixer	1	
28	1090050649	Remote Controller	1	Not shown in Explosion view
29	1070060003	Remote Controller Supporter	1	
30	1190320879	Indoor Carton	1	
31	1191990102	Left Foaming	1	
32	1191990103	Right Foaming	1	

Indoor Unit- DSH 105 R/C

No.	Part No.	Part Name	Q'ty	Remark
1	1080030003	Installation Plate	1	
2	1210250103	Base	1	
3	1070020017	Cross Fan	1	
4	1070100010	Bearing Mount	1	
5	1210231201	Evaporator	1	
6	1070251833	Water Drainage Assembly	1	
7	1070321035	Vertical Vane Assembly	2	
8	1070251841	Face Frame	1	
9	1070320112	Screw Cover	2	
10	1070250106	Air Filter	2	
11	1070251941	Front Panel	1	
12	1170120042	Power Supply Cord	1	
13	1070251837	Vane	1	
14	1070110011	Drainage Hose	1	
15	1070321024	Display PCB Cover	1	
16	1090320291	Display PCB(Digital)	1	
17	1070321181	Display PCB Box	1	
18	1070040004	Cable Clamp	1	
19	1170020011	Vane Motor	1	
20	1090250016	Main PCB(Digital)	1	
21	1073030201	Sensor Holder	1	
22	1070320113	Electrical Box	1	
23	1070320111	Indoor Motor Cover	1	
24	1170030047	Indoor Motor	1	
25	1170240001	Transformer	1	
26	1170230001	Indoor Sensor Assembly	1	
27	1070320101	In And Out Pipe Fixer	1	
29	1090050649	Remote Controller	1	Not shown in Explosion view
29	1070060003	Remote Controller Supporter	1	
30	1190250885	Indoor Carton	1	
31	1191990102	Left Foaming	1	
32	1191990103	Right Foaming	1	

Part List**Indoor Unit- DSH 265 R/C**

No.	Part No.	Part Name	Q'ty	Remark
1	1080030001	Installation Plate	1	
2	1070701047	Base	1	
3	1070020014	Cross Fan	1	
4	1070100010	Bearing Mount	1	
5	1110050321	Evaporator	1	
6	1070701048	Water Drainage Assembly	1	
7	1070701050	Vertical Vane Assembly A	1	
	1070701051	Vertical Vane Assembly B	1	
8	1070701060	Face Frame	1	
9	1073090111	Screw Cover	3	
10	1073090112	Left Air Filter	1	
	1073090113	Right Air Filter	1	
11	1070701284	Front Panel	1	
12	1070700511	Display PCB Cover	1	
13	1300700890	Display PCB(Digital)	1	
14	1073090114	Electrical Box Cover	1	
15	1070701052	Vane A	1	
16	1070701053	Vane B	1	
17	1070110011	Drainage Hose	1	
18	1074060118	Cable Clamp	1	
19	1170020041	Vane Motor	2	
20	1090700403	Main PCB(Digital)	1	
21	1073030201	Sensor Holder	1	
22	1073090121	Electrical Box	1	
23	1073090120	Indoor Motor Cover	1	
24	1170030048	Indoor Motor	1	
25	1173090107	Transformer	1	
26	1170230001	Indoor Sensor Assembly	1	
27	1090050649	Remote Controller	1	Not shown in Explosion view
28	1070060003	Remote Controller Supporter	1	
29	1190500155	Indoor Carton	1	
30	1150700001	Left Foaming	1	
31	1150700002	Right Foaming	1	
32	1190060021	Middle Pasteboard Supporter	1	
33	1190060021	Middle Foaming Supporter	1	

Part List**Outdoor Unit- DSH 95 R/C**

No.	Part No.	Part Name	Q'ty	Remark
1	1083510901	Grille	1	Optional
2	1081990014	Top Cover	1	
3	1110061174	Condenser	1	
4	1081990018	Outdoor Motor Supporter	1	
5	1170040062	Outdoor Motor	1	
6	1070030006	Propeller Fan	1	
7	1081990011	Left Grille Supporter	1	
8	1080320147	Left airproof plate	1	
9	1081990016	Front Plate	1	
10	1071990044	Fan Guard	1	
11	1100060199	Compressor And It Accessories	1	
12	1120110002	4-way Valve	1	
13	1120200477	4-way Valve Assembly	1	
14	1091990046	Base	1	
15	1081990012	Right Plate	1	
16	1120120008	Two-way Valve	1	
17	1081990013	Valve Supporter	1	
18	1120130011	Three-way Valve	1	
19	1073521301	Electrical Box Cover	1	
20	1070040001	Cable Clamp(ϕ 6)	1	
21	1070040002	Cable Clamp(ϕ 7)	1	
22	1170500131	Terminal	1	
23	1170100031	Fan Motor Capacitor	1	
24	1170100014	Compressor Capacitor	1	
25	1080010006	Capacitor Strip	1	
26	1080020001	Electrical Parts Box	1	
27	1120200476	Capillary Assembly	1	
28	1190070014	Base Carton	1	Not shown in the Explosion view.
29	1190200313	Cabinet Carton	1	
30	1190070016	Base Foaming	1	
31	1190070015	Cover Forming	1	

Part List**Outdoor Unit- DSH 105 R/C**

No.	Part No.	Part Name	Q'ty	Remark
1	1071990038	Grille	1	Optional
2	1081990014	Top Cover	1	
3	1300230293	Condenser	1	
4	1081990018	Outdoor Motor Supporter	1	
5	1170040071	Outdoor Motor	1	
6	1070030006	Propeller Fan	1	
7	1081990011	Left Grille Supporter	1	
8	1081990016	Front Plate	1	
9	1071990044	Fan Guard	1	
10	1100170010	Compressor And It	1	
11	1120110002	4-way Valve	1	
12	1120250991	4-way Valve Assembly	1	
13	1091990046	Base	1	
14	1081990012	Right Plate	1	
15	1120120008	Two-way Valve	1	
16	1081990013	Valve Supporter	1	
17	1120130011	Three-way Valve	1	
18	1073521301	Electrical Box Cover	1	
19	1070040001	Cable Clamp(ϕ 6)	1	
20	1070040003	Cable Clamp(ϕ 8)	1	
21	1170500131	Terminal	1	
22	1170100031	Fan Motor Capacitor	1	
23	1170100014	Compressor Capacitor	1	
24	1080010006	Capacitor Strip	1	
25	1081990010	Electrical Parts Box	1	
26	1120250988	Capillary Assembly	1	
27	1081990019	Partition plate	1	
28	1190070014	Base Carton	1	Not shown in the Explosion view.
29	1190070008	Cabinet Carton	1	
30	1190070016	Base Foaming	1	
31	1190070015	Cover Forming	1	

Outdoor Unit- DSH 135 R/C

No.	Part No.	Part Name	Q'ty	Remark
1	1071990039	Grille	1	Optional
2	1080320105	Top Cover	1	
3	1110060973	Condenser	1	
4	1080050004	Outdoor Motor Supporter	1	
5	1170040058	Outdoor Motor	1	
6	1070030033	Propeller Fan	1	
7	1080050001	Left Grille Supporter	1	
8	1080320113	Front Plate	1	
9	1080320112	Fan Guard	1	
10	1100170028	Compressor And It Accessories	1	
11	1120110002	4-way Valve	1	
12	1120320915	4-way Valve Assembly	1	
13	1081990209	Base	1	
14	1080050002	Right Plate	1	
15	1120120016	Two-way Valve	1	
16	1080050003	Valve Supporter	1	
17	1120130021	Three-way Valve	1	
18	1073551103	Electrical Box Cover	1	
19	1070040002	Cable Clamp(ϕ 7)	1	
20	1070040003	Cable Clamp(ϕ 8)	1	
21	1170500131	Terminal	1	
22	1170100010	Fan Motor Capacitor	1	
23	1170100003	Compressor Capacitor	1	
24	1080010006	Capacitor Strip	1	
25	1081990010	Electrical Parts Box	1	
26	1120320914	Capillary Assembly	1	
27	1081990019	Partition plate	1	
29	1190070017	Base Carton	1	Not shown in the Explosion view.
30	1190320718	Cabinet Carton	1	
31	1190070019	Base Foaming	1	
32	1190070018	Cover Forming	1	

Outdoor Unit- DSH 195 R/C

No.	Part No.	Part Name	Q'ty	Remark
1	1083520101	Grille	1	Optional
2	1081990056	Top Cover	1	
3	1110060506	Condenser	1	
4	1081990060	Outdoor Motor Supporter	1	
5	1170040100	Outdoor Motor	1	
6	1070030040	Propeller Fan	1	
7	1081990053	Left Grille Supporter	1	
8	1081990058	Front Plate	1	
9	1081990059	Fan Guard	1	
10	1100110020	Compressor And It Accessories	1	
11	1120110003	4-way Valve	1	
12	1120520760	4-way Valve Assembly	1	
13	1081990249	Base	1	
14	1081990054	Right Plate	1	
15	1120120016	Two-way Valve	1	
16	1081990055	Valve Supporter	1	
17	1120130024	Three-way Valve	1	
18	1073551103	Electrical Box Cover	1	
19	1070040001	Cable Clamp ϕ 6	1	
20	1070040003	Cable Clamp ϕ 8	1	
21	1170500131	Terminal	1	
22	1170100030	Fan Motor Capacitor	1	
23	1170100004	Compressor Capacitor	1	
24	1080010006	Capacitor Strip	1	
25	1081990010	Electrical Parts Box	1	
26	1120501129	Capillary Assembly	1	
27	1081990071	Partition plate	1	
28	1174561802	Outdoor sensor	1	Not shown in the Explosion view.
29	1190070064	Base Carton	1	
30	1190500898	Cabinet Carton	1	
31	1190070066	Base Foaming	1	
32	1190070124	Cover Forming	1	

Part List

Outdoor Unit- DSH 265 R/C

No.	Part No.	Part Name	Q'ty	Remark
1	1083520101	Grille	1	Optional
2	1081990056	Top Cover	1	
3	1110060885	Condenser	1	
4	1081990060	Outdoor Motor Supporter	1	
5	1170040100	Outdoor Motor	1	
6	1070030040	Propeller Fan	1	
7	1081990053	Left Grille Supporter	1	
8	1081990258	Front Plate	1	
9	1071990096	Fan Guad	1	
10	1100040068	Compressor And It Accessories	1	
11	1120110001	4-way Valve	1	
12	1120701279	4-way Valve Assembly	1	
13	1080500328	Base	1	
14	1081990054	Right Plate	1	
15	1120120011	Two-way Valve	1	
16	1081990055	Valve Supporter	1	
17	1120130013	Three-way Valve	1	
18	1073551103	Electrical Box Cover	1	
19	1074060118	Cable Clamp	1	
20	1170200054	Terminal	1	
21	1170100030	Fan Motor Capacitor	1	
22	1170100007	Compressor Capacitor	1	
23	1080010006	Capacitor Strip	1	
24	1081990072	Electrical Parts Box	1	
25	1174561801	AC Contactor	1	
26	1120701269	Capillary Assembly	1	
27	1081990071	Partition plate	1	Not show in the explosion
28	1174561802	Outdoor Defrost Sensor	1	
29	1190500898	Cabinet Carton	1	
30	1190070124	Cover Forming	1	
31	1190070064	Base Carton		
32	1190070066	Base Foaming		